



# EL series twin system

EL-120W / EL-150W  
EL-200W / EL-250W

### Product characteristics

- Integrated overload protection
- Protective switch inclusive
- Optional with fault alarm lamp and integrated signal cable
- Twin outlet for alternative port position

### Dimensions

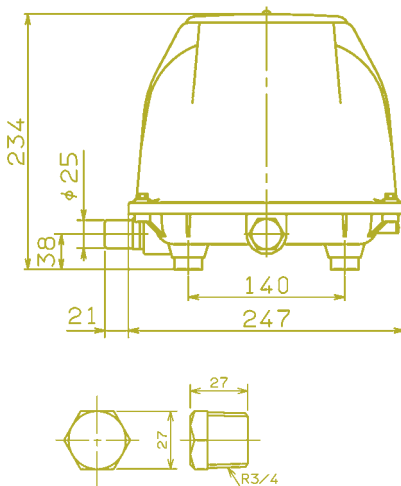
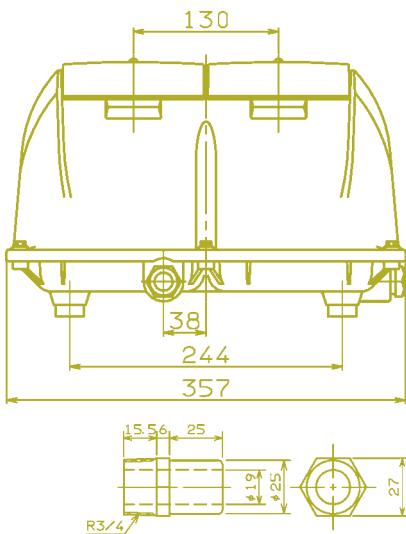

### Technical data

Model		EL-120W	EL-150W	EL-200W	EL-250W	
Air flow <sup>1)</sup>	l/min	0 mbar	240	290	330	360
		50 mbar	215	258	300	330
		100 mbar	185	225	265	300
		150 mbar	151	194	235	270
		200 mbar	117	159	205	240
		250 mbar	80	121	170	208
Voltage/Frequency	V/Hz	230/50	230/50	230/50	230/50	
Power consumption	W	200 mbar	129	149	216	240
Noise level	dB(A)		43	44	45	55
Dimensions	mm	L x W x H				268.5 x 357 x 234
Connection	mm	Ø outside	25	25	25	25
Net weight	kg		16	16	16	16

<sup>1)</sup> Product performance may vary +/- 10% from performance curves

### Performance data

Optimal operating span

